

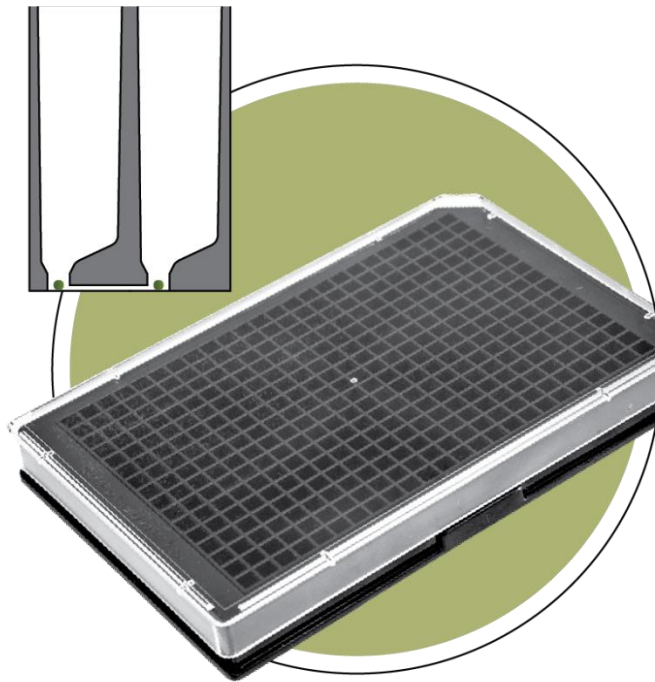

Akura™ Twin Microplate

Technical Specifications



SPEC007, April 2023

Akura™ Twin Microplate Specifications

Article number:	CS-PE13
Product name:	Akura™ Twin Microplate
Pack size:	5x Akura™ Twin Microplates with lid, sterile, ultra-low attachment (ULA) coated wells
Plate & lid material:	Black-walled Polystyrene body glued to transparent, continuous, 188 µm COP (Cyclo-olefin-polymer) membrane, Polystyrene lid
ULA coating:	ULA coated Akura™ plate surfaces are hydrophilic, neutrally charged and ensure long-term maintenance (>4 weeks) of 3D cell cultures.

Plate Dimensions:

Plate length:	127.76 mm
Plate width:	85.48 mm
Height of plate:	15.15 mm
Height of well:	11.93 mm
Skirt height:	3.118 mm
Diameter well bottom:	1.00 mm
Thickness well bottom:	0.188 mm
A1 well center to top distance:	8.99 mm
A1 well center to side distance:	12.13 mm
A1 cavity center to top distance:	9.89 mm
A1 cavity center to side distance:	12.13 mm
Well center to cavity center offset:	0.90 mm
Working volume:	40-50 µl
Well-to-well distance:	4.5 mm
SureXchange™ tip position:	0.7 mm (horizontal offset from well center)
	9.86 mm (z-distance to plate top)

Product Description:

The Akura™ Twin Plate format is compliant with standard microplate definitions as specified by the SLAS Microplate Standards Advisory Committee ANSI SLAS 1-2004 (R2012). The 384 wells are arranged in 16 rows and 24 columns, identified by alphanumeric well markings on the left side from top to bottom (A-P) and on the top from left to right (1-24). Plate orientation notches are located at the A1 and P1 well corners (Figure 2). Individual wells show a regular wide opening at the top narrowing down into a small, asymmetric cavity at the well bottom, with a flat optically clear base (Figure 1), designed to accommodate spheroids of up to 1 mm in diameter. Always two wells are fluidically connected through a microchannel at the bottom of the well enabling cross-talk between the two wells. The channel height of 0.09 mm prevents spheroids of travelling through the microchannel. In the first (A) and last row (P), the microchannels are oriented along the row. In rows B to O the microchannels are oriented column-wise. Spheroids in the wells and cells in the well and microchannel can be observed using standard imaging equipment. The Akura™ Twin Microplate Technical Specifications provides additional details about plate design and dimensions.

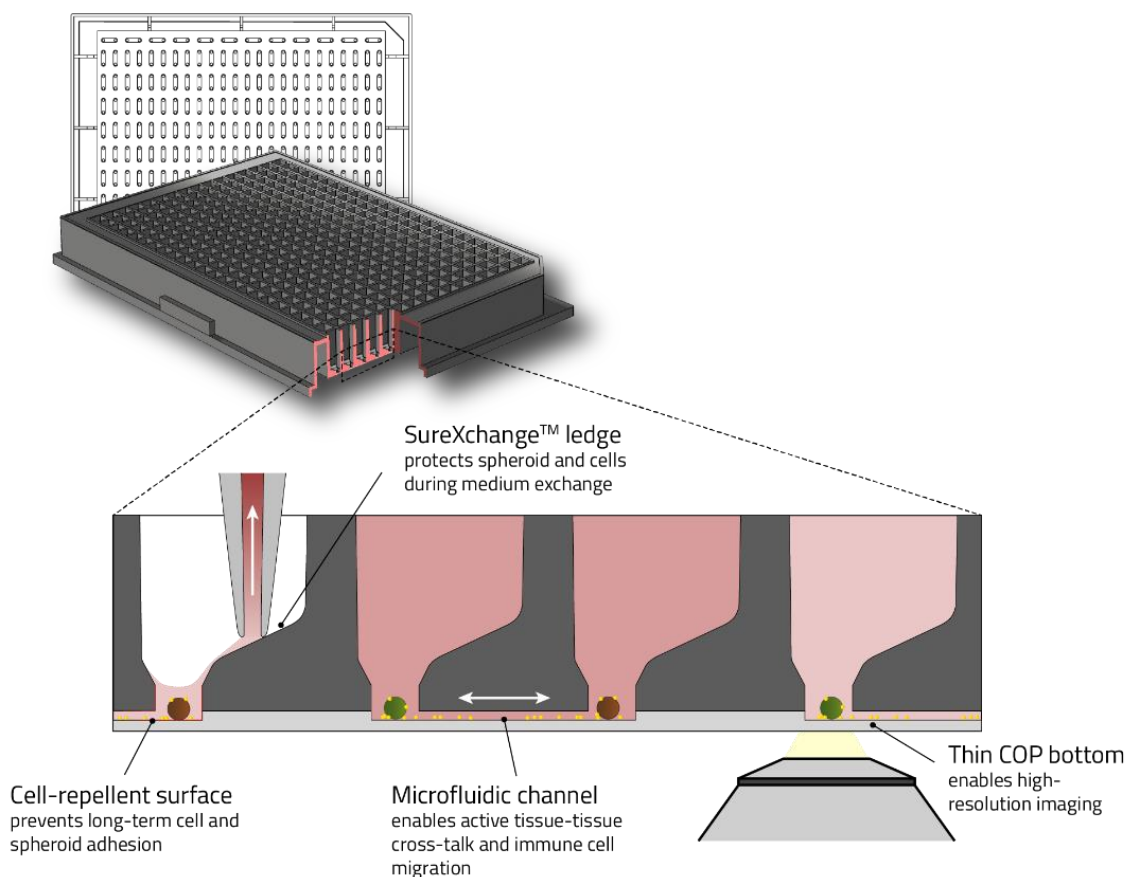

Figure 1: Description of the Akura™ Twin Plate: The cross-section illustrates design and features of the plate. The plate body originates from the Akura™ 384 Spheroid Microplate extended with a microfluidic channel between two wells.

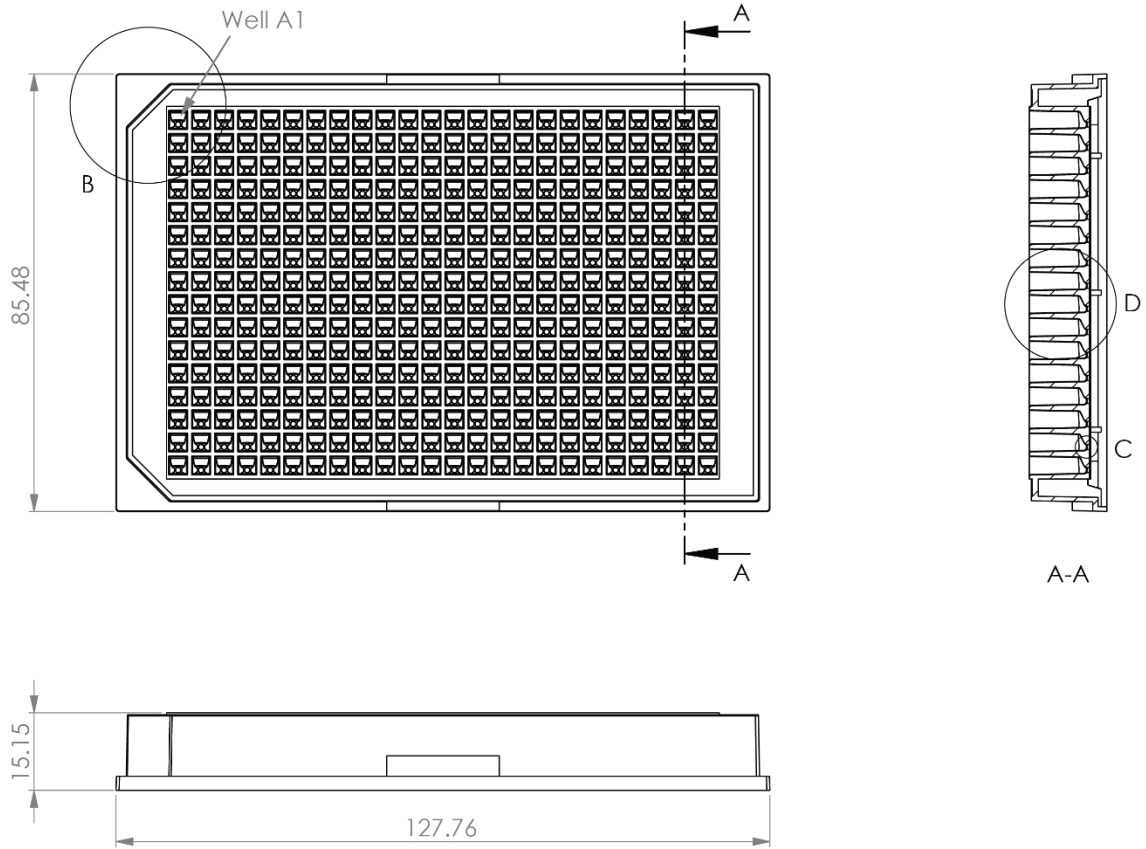

Figure 2: Plate top and side view. Row cross-section.

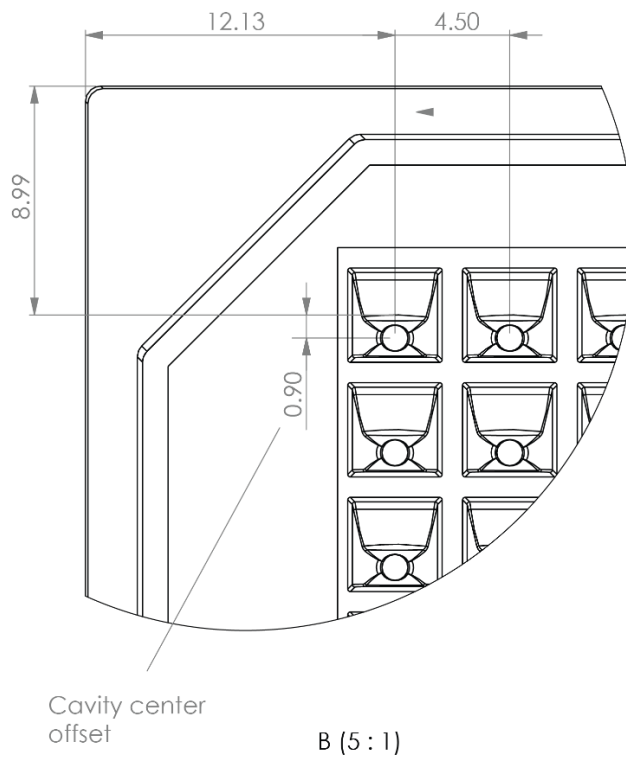

Figure 3: Detail B showing dimensions of the well A1 at the plate corner.

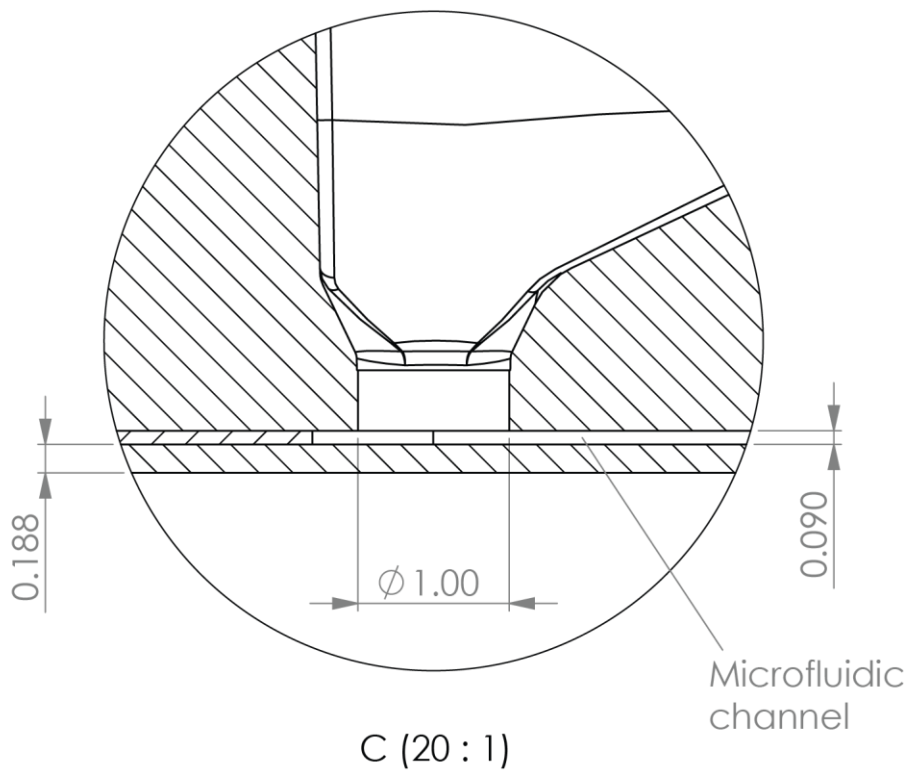

Figure 4: Detail C of the row cross-section showing the design and dimensions of the cavity and underlying microchannel.

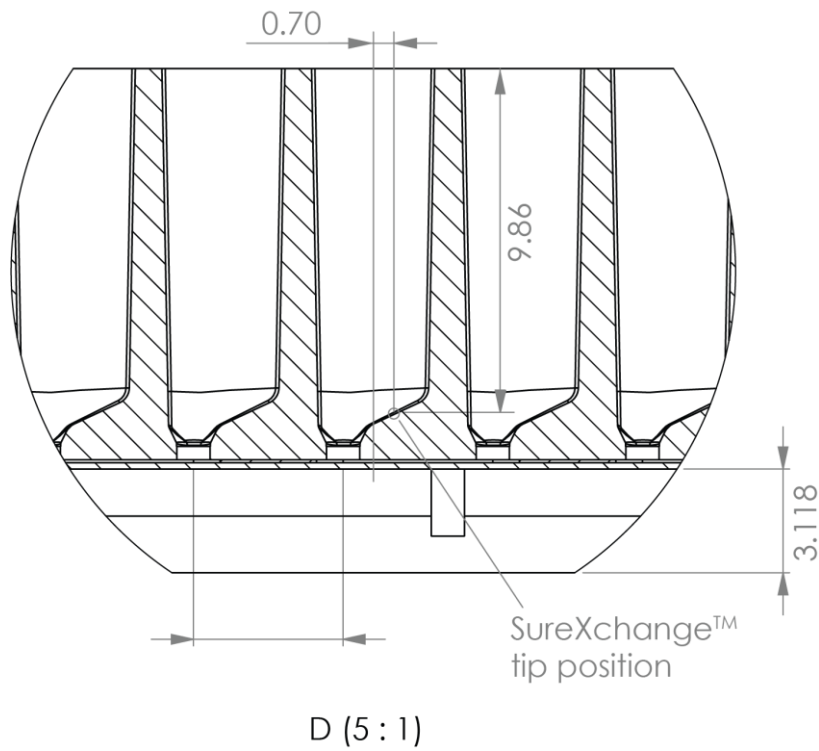

Figure 5: Detail D of the row cross-section showing the complete well with SureXchange™ tip position.

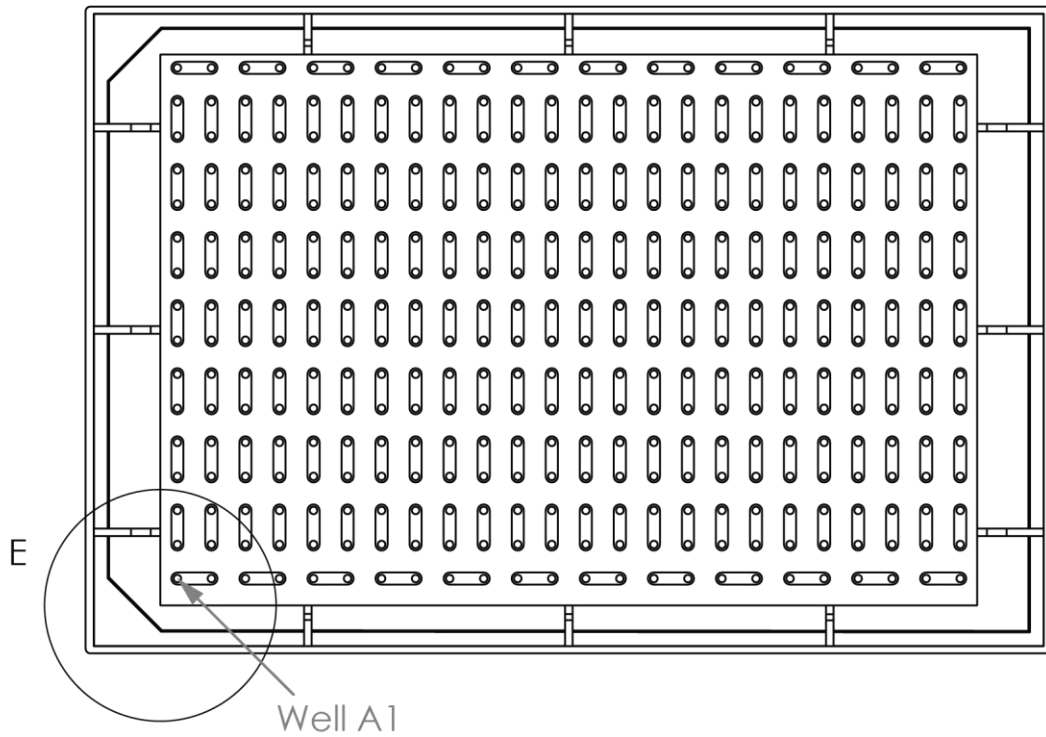

Figure 6: Bottom view of the plate illustrating orientation of the 192 Twin wells.

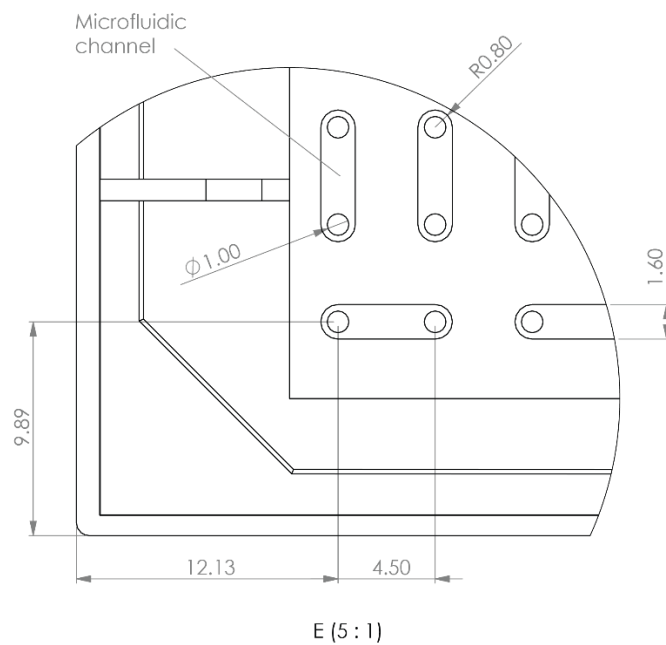

Figure 7: Detail E of the bottom view showing dimensions of the well A1 at the plate corner.



InSphero AG
Schlieren, Switzerland

InSphero Inc.
Brunswick, ME, USA

If you have more questions, please refer to
the **FAQs** section on shop.insphero.com

Sign up for latest news and updates at
insphero.com/newsletter

Follow us on LinkedIn and Twitter

InSphero is ISO 9001:2015 certified

All rights reserved, © 2021 InSphero AG.
3D InSight, Akura and InFloat are
trademarks of InSphero AG. For life
science research only. Not for use in
diagnostic procedures.