

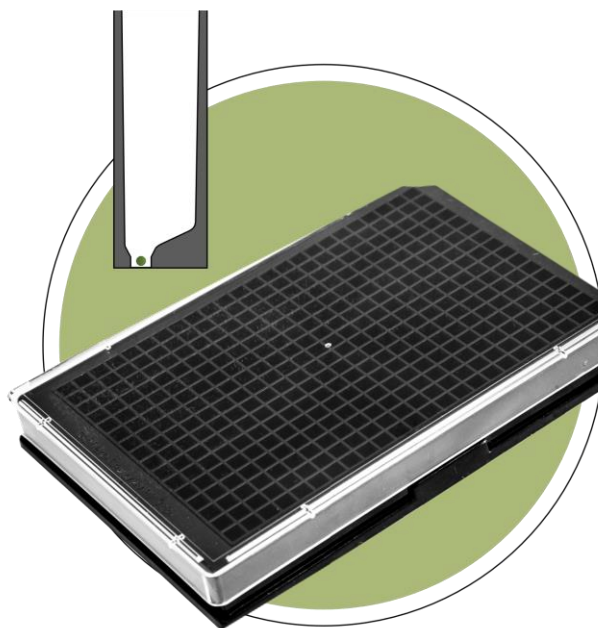

Akura™ 384 ImagePro

Technical Specifications



SPEC003, February 2023

Akura™ 384 ImagePro Specifications

Article number:	CS-09-003-02
Product name:	Akura™ 384 ImagePro
Pack size:	10x Akura™ 384 Plates with lid, sterile, ultra-low attachment (ULA) coated wells
Plate & lid material:	Black-walled polystyrene body bonded to transparent, continuous, 25 µm gas-permeable FEP (fluorinated ethylene propylene) membrane, Polystyrene lid
ULA coating:	ULA coated Akura™ plate surfaces are hydrophilic, neutrally charged and promote the formation and long-term maintenance (>4 weeks) of 3D cell cultures.

Plate Dimensions:

Plate length:	127.76 mm
Plate width:	85.48 mm
Height of plate:	14.80 mm
Height of well:	11.93 mm
Skirt height:	2.87 mm
Diameter well bottom:	1.00 mm
Thickness well bottom:	0.025 mm
A1 to top offset:	9.89 mm
A1 to side offset:	12.13 mm
Well center to cavity center offset:	0.90 mm
Working volume:	40-50 µl
Well-to-well distance:	4.5 mm
Refractive index FEP membrane:	1.34

Product Description:

The Akura™ 384 Plate format is compliant with standard microplate definitions as specified by the SLAS Microplate Standards Advisory Committee ANSI SLAS 1-2004 (R2012). The 384 wells are arranged in 16 rows and 24 columns, identified by alphanumeric well markings on the left side from top to bottom (A-P) and on the top from left to right (1-24). Plate orientation notches are located at the A1 and P1 well corners (Figure 1A). Individual wells show a regular wide opening at the top narrowing down into a small, asymmetric cavity at the well bottom, with a flat optically clear base (Figure 1B), designed to accommodate spheroids of up to 1 mm in diameter. Spheroids in wells can be observed using standard imaging equipment (Figure 1C, D). The Akura™ 384 ImagePro Technical Specifications provides additional details about plate design and dimensions (Figure 2-4).

A Akura™ 384 Plate design

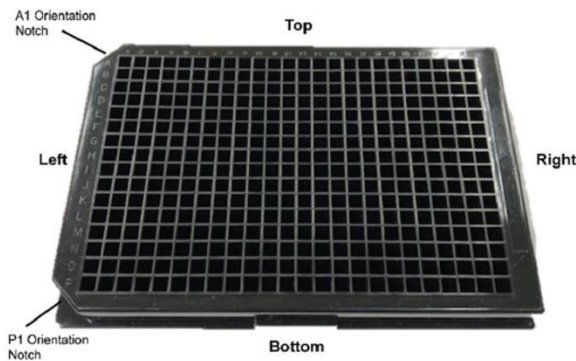

B Well dimensions and spheroid position

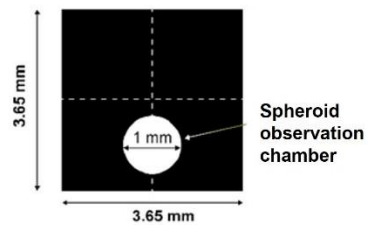

C Imaging scans of spheroids in wells

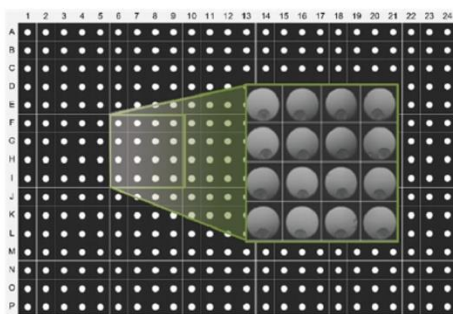

D Spheroid in 1 mm observation chamber

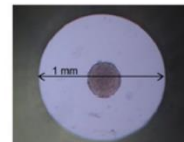

Figure 1: A. Akura™ 384 Plate. B. Overhead view of well dimensions and 1 mm spheroid observation chamber. C. Imaging scan of an Akura™ 384 Plate shows one spheroid per well and the position of each spheroid within the observation chamber. D. Image of a spheroid within the 1 mm spheroid observation chamber.

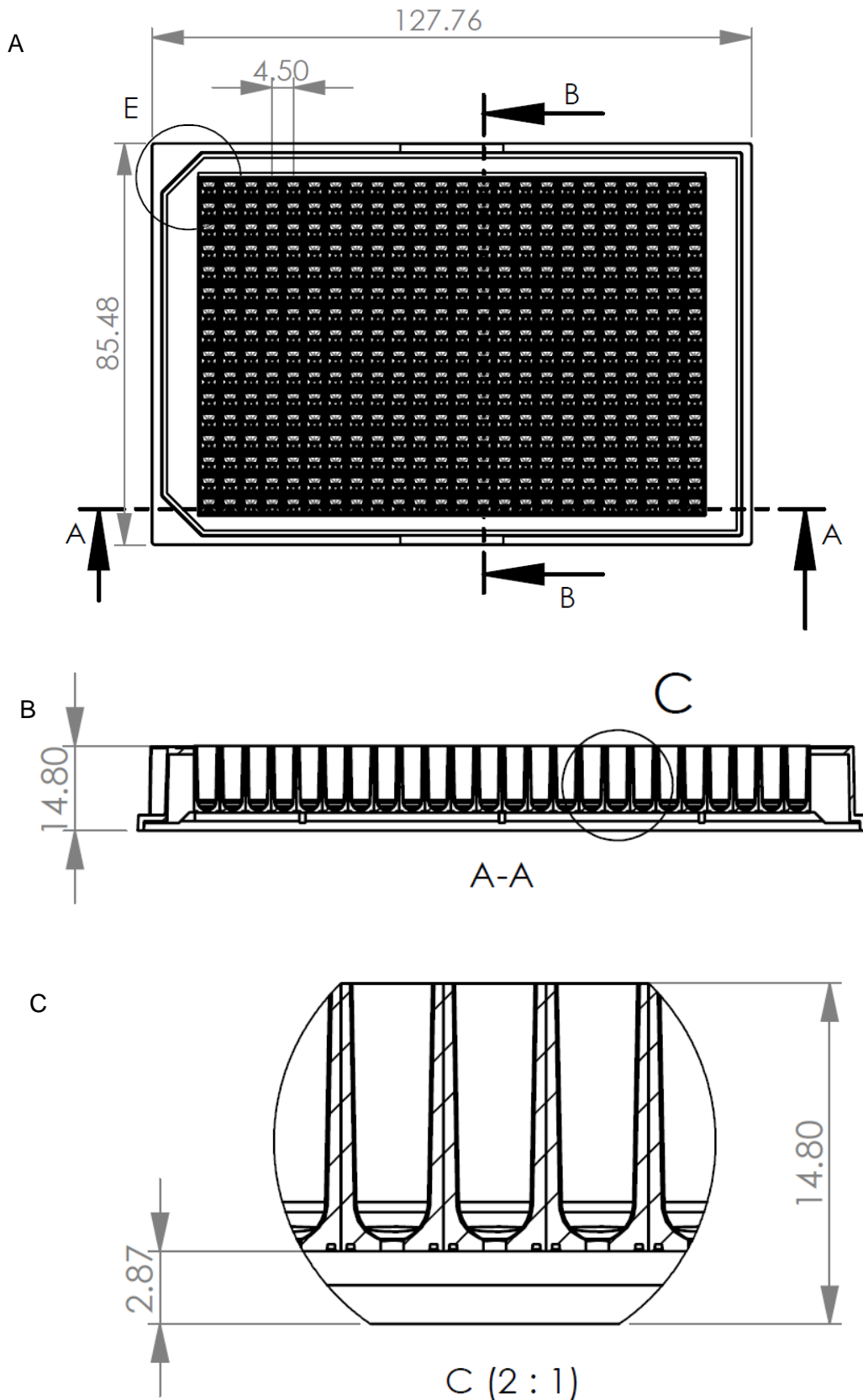

Figure 2: A. Plate layout. B. Row cross section with plate height and C. Skirt height (distance between plate bottom and rim).

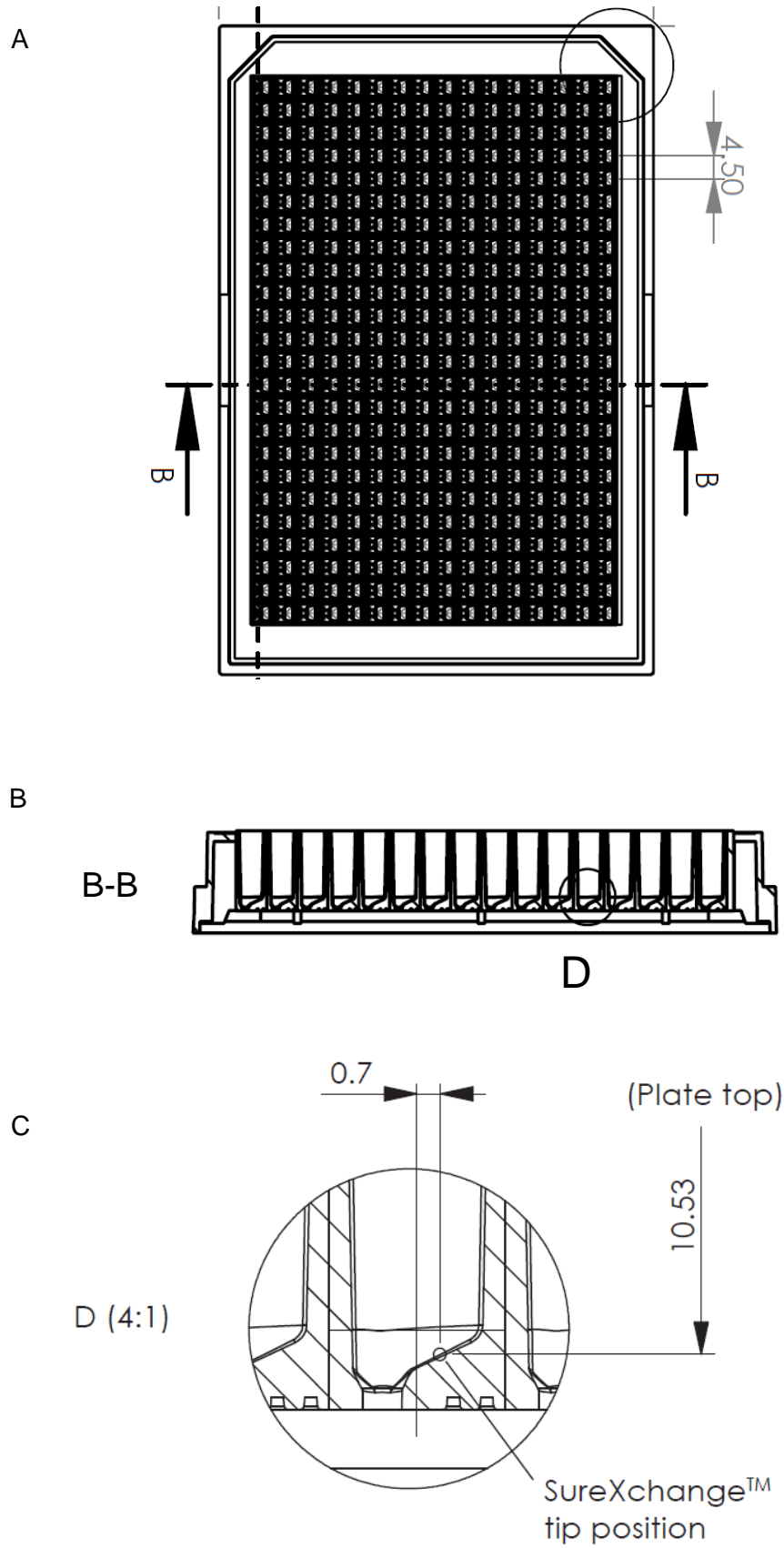

Figure 3: A. Vertically oriented plate layout. B. Row cross section and C. Well cross section with SureXchange™ tip position in mm.

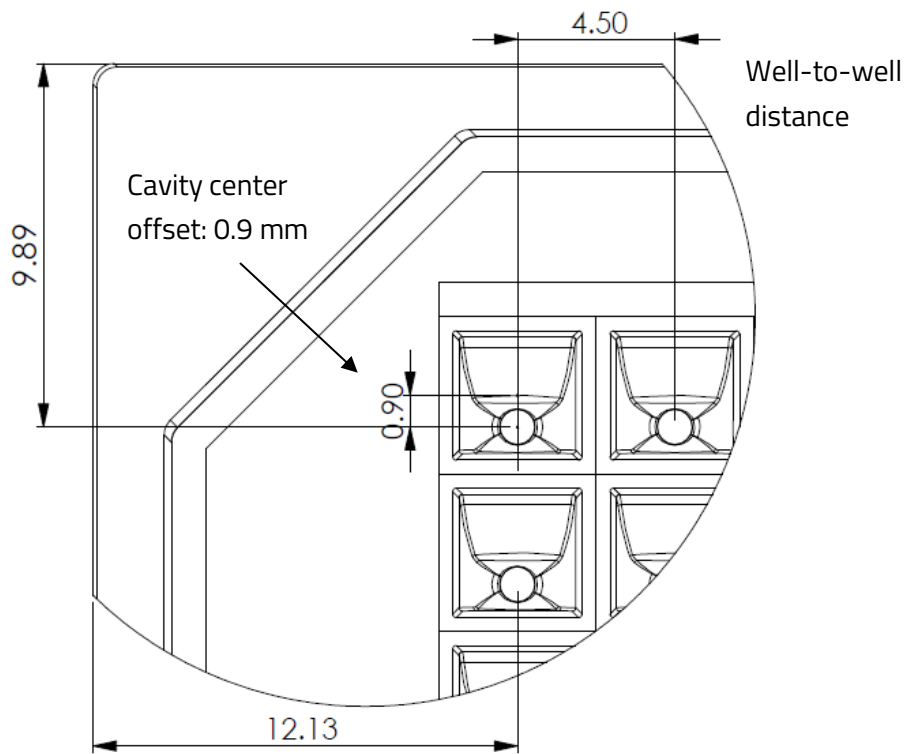

Figure 4: Top-down view showing cavity center offset.

Akura™ 384 ImagePro restrictions:

Biocompatible glue is used to adhere the gas-permeable membrane to the plate frame. The glue shows auto-fluorescent properties at low wavelengths (e.g. DAPI/Hoechst). Depending on the imaging parameter and staining conditions used, a fluorescent ring around the well may be detected (Figure 5A).

The skirt height of the Akura™ 384 Plate is 2.87 mm. The skirt height is the distance between the well bottom (the 25 µm gas-permeable membrane) and the plate skirt (Figure 5B). This design may restrict certain high NA objectives and immersion objectives to reach the outer wells of the plate.

A Fluorescent ring around well



B Plate Skirt Height

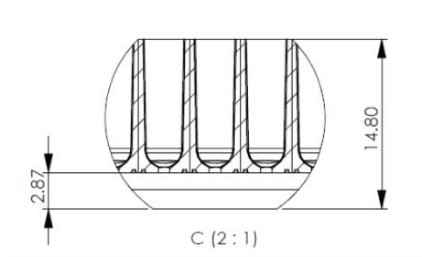

Figure 5: A. Fluorescent ring around well in DAPI/Hoechst channel. B. Skirt height of 2.87 mm does not allow high NA and water immersion objectives to be used for outer wells.



InSphero AG
Schlieren, Switzerland

InSphero Inc.
Brunswick, ME, USA

If you have more questions, please refer to
the **FAQs** section on shop.insphero.com

Sign up for latest news and updates at
insphero.com/newsletter

Follow us on LinkedIn and Twitter

InSphero is ISO 9001:2015 certified

All rights reserved, © 2021 InSphero AG.
3D InSight, Akura and InFloat are
trademarks of InSphero AG. For life
science research only. Not for use in
diagnostic procedures.